

KayaArm Assembly/Operating Instructions B8 (2021-07-19) © Wirsig Enterprises Inc.

While the assembly and operation of the KayaArm is largely intuitive this manual provides detailed instructions to ensure optimum and safe operation. KayaArm: Can patent 2,706,497; US patent 8,381,673.

IMPORTANT:

- BEFORE USING YOUR KayaArm, READ AND UNDERSTAND THIS OWNER'S MANUAL.
- SAVE THESE INSTRUCTIONS---THIS OWNERS MANUAL CONTAINS IMPORTANT SAFETY INSTRUCTIONS
- WIRSIG ENTERPRISES INC. AND THE RETAILER CANNOT BE HELD RESPONSIBLE FOR DAMAGES OR INJURY SUFFERED AS THE RESULT OF FAILURE TO FOLLOW THE INSTRUCTIONS AS SET OUT HERE-IN.

Warranty:

This product carries a **one-(1)-year** warranty from date of purchase against defects in workmanship and materials. This product is not guaranteed against wear, breakage or misuse. Should this product become defective within the stated warranty period, contact Wirsig Enterprises Inc. at www.wirsigenterprises.com for an evaluation of the situation to figure out what needs to be done to take care of things including free shipment of replacement parts. This warranty does not cover labour costs for any repairs and generally does not cover product return shipping costs. Exchanges or repairs made under this warranty do not extend its limit.

1. Assembly Instructions for KayaArm:

- Tools required:
 - Two 1/2" wrenches
 - Two 7/16" wrenches
 - #2 or #3 Phillips screw driver
 - Screw driver for driving deck screws.
- Other Hardware Required:
 - 6 deck screws (#8 or #10) for attaching the KayaArm to the dock
- Parts List (Refer to Figure 1):
 - One of each of the following: mast (1), shoe (2), arm (3), angle (4), cap (5), and chain (6)
 - Two of each of the following: 1/4"-20 x 3/4" SS hex head bolt (7), 1/4"-20 x 3/4" SS flat head bolt (8), 5/16"-18 x 1" SS hex head bolt (9), 5/16"-18 SS Nylock nut (10), 1/4" SS flat washer (12) and tapered cedar shims (13)
 - Four of the following: 1/4"-20 SS Nylock nut (11)

Note that for orientation purposes the chain slot identifies the top end of the mast.

- Completing the assembly (Refer to Figure 1):
 - For additional visual information visit <https://kayaarm.com/documentation/assembly-instructions/>
 - Using 2 flat head bolts (8) and 2 Nylock nuts (11) fasten the angle (4) onto the mast (1) through the upper set of holes in the mast flanges.
 - Using 2 hex head bolts (9) and 2 Nylock nuts (10) fasten the bent arm (3) onto the bottom of the shoe (2). **Note that the bolts pass through the arm plate first and then the shoe otherwise binding may occur during hoisting.**
 - Slide the shoe/arm assembly into the track provided in the mast.
 - Using hex head bolts (7) washers (12) and Nylock nuts (11) fasten one end of the chain (6) to the top of the mast and the other end of the chain to top of the shoe.
 - **Be sure to tighten all nuts securely.**

2. Mounting the KayaArm onto a fixed or floating dock: to watch installation video search HOW TO INSTALL KAYAARM ONTO A DOCK - Youtube

- While the water space beside the dock needs to be large enough for the kayak, the actual dock space required for the KayaArm and for entry/exit maneuvers can be as little as 3 to 5 ft (1 to 1 1/2 meters).
- Mounting details will vary depending on dock construction. The following is one example for mounting on a straight sided wooden dock (Refer to Figures 1 & 2):
 - Place the assembled KayaArm onto the edge of dock and fasten it to the dock using 4 deck screws (not provided) into the top surface of the angle (4). Fit the cedar shims into the approximately 1/4" space between the back of the mast and the vertical surface of the dock (see Figure 2) at a location directly behind the lower holes in the mast flanges. HINT: Push the tapered shims simultaneously one from each side of the mast and one in front of the other, into the space behind the mast to a distance where this space is filled when the mast is vertical. Install 2 deck screws (not provided) into the lower flange holes. Optionally install more deck screws through additional holes provided in angle (4).

3. Mounting the KayaArm to a ladder on a fixed or floating dock:

- The KayaArm mounted as above on a dock is functional to a water level about 30" below the top of the dock. For water levels below that you may attach the KayaArm to the side of a ladder with two bolts (not provided) through holes provided in the mast (1). See photos on our website under "Additional Mounting and Use /instructions".
- As an alternative to mounting the KayaArm to the side of a ladder, we made a block about 18" long out of two 2x4s and two 2x6s for mounting the KayaArm onto the dock beside a ladder. The inner 2x6, which may need to be longer than 18", must be fastened (with the 5.5" side of the 2x6 against the side of the dock) firmly onto the side of the dock. Using 2.5" to

3" deck screws, then mount the two 2x4s spaced apart and perpendicular to the flat surface of the inner 2x6 so as to provide the sides of the box. It would be easier to fasten these 2x4s to the 2x6 before fastening that 2x6 to the dock. Then mount the outer 2x6 to complete the box. Then onto the outer 2x6 of this block I mounted the KayaArm. With this arrangement the aluminum angle and the wood shims provided are not needed.

CAUTION:

- DO NOT DIVE OR JUMP OFF THE DOCK INTO THE WATER NEAR THE INSTALLED KayaArm. DOING SO MAY CAUSE PERSONAL INJURY.
- BE AWARE OF THE PRESENCE OF THE PROJECTING ARM BESIDE THE DOCK AT AN INSTALLED KayaArm.
- BE AWARE OF THE MAST AND MOUNTING BRACKET AFIXED TO THE SIDE OF THE DOCK AS OBJECTS NOT TO BUMP INTO OR TRIP OVER.
- IF THE DOCK SPACE AT THE KayaArm IS NEEDED FOR OTHER PURPOSES (E.G. SWIMMING OR MOTOR BOATING) SLIDE THE TETHERED BENT ARM AND SHOE ASSEMBLY UP OUT OF THE TOP OF THE MAST AND HANG IT OUT OF THE WAY IN THE WATER BESIDE THE DOCK.

4. Suggested Operating Instructions:

- **Arm height:** By gripping and lifting on the chain (6) adjust and fix the arm height to the desired level relative to the water surface. Generally the outboard end of the arm should be about at the water surface or a little above it. For floating docks it may need to be a little higher. At no time should the arm be completely out of the water as this makes sliding off difficult aside from putting excessive strain on the arm joint especially when sliding off the arm during launch.
- For **entry and launch** maneuver the kayak into position over the arm (3) with the arm usually about 4 to 10" forward of the cockpit although this depends on the shape of the cockpit. Alternatively, the arm should be about 1 to 2 ft. forward of where you step into the kayak---the arm must not be under foot. Prior to step-in the kayak should still be mainly floating. (If you have access to the internet see demo video clips on our YouTube page)
- Place the paddle on the dock beside the kayak
- With a steadying hand on the mast (1) step into the kayak. At this point the kayak should be in contact with and stabilized by arm (3). HINT: If it is not stabilized get out and raise the arm in increments of one chain link until it is stabilized when you step into the kayak.
- Once standing on both feet in the stabilized kayak let go of the mast and with both hands on the gunnels, maneuver yourself to the normal sitting position.
- Pick up the paddle and push off with one hand from the dock in the reverse direction. HINT: Difficulty in pushing off may be due to the arm height being too high.
- The **return to dock and exit procedure** is the reverse of the above entry and launch procedure. This includes using only the gunnels (not the mast) to bring yourself from a sitting to a standing position. Do not use the mast as a steadying post until you are ready to step out.
- If maneuvering from a sitting to a standing position is too difficult, try rotating your body (by gripping the gunnels and not the mast or dock) to a kneeling position in the cockpit of the stabilized kayak and then move out onto the dock.

5. KayaArm arm covering:

Experience demonstrates that no covering on the arm works well for most Kayaks. For some hulls, (for example fiberglass, Kevlar or composite hulls) to avoid hull marking a covering of inexpensive black polyethylene pipe is very effective. The gentle "V" shape of the arm along with the black polyethylene cover tends to spread the load and thus a concern for possible stiff hull damage has not been observed. But as a precaution in the case of stiff hulls the kayaker should be sure to have the arm forward of the cockpit and not under foot when stepping into or out of the kayak.

A polyethylene cover over the arm can consist of the following:

- Cut two pieces black utility grade polyethylene pipe 11" in length. Pipe diameter 1.5" utility grade is easier to work with than thicker grades.
- Slit the two pipe pieces and slip them over the top surface of each wing of the arm. Use zip ties to hold in place.

6. KayaArm shoe covering:

As with the arm no covering on the shoe works well for most Kayaks. If needed (fiberglass, Kevlar or composite kayaks), a 12" long piece of slit 1/2" polyethylene water pipe (eg PEX) slipped over the shoe flange works well.

7. Two KayaArm Instructions (See photos at <https://kayaarm.com/>)

- **Kayak storage at dock:**
 - Install two KayaArms at your dock about 5 ft. apart. Set one arm at normal use height and the other well below the water surface.
 - **HINT: It is beneficial to apply waterproof grease (not WD40) on the back of the shoe, so it slides freely in the channel**
 - Once you have exited the kayak, and the kayak is resting on the front KayaArm, raise the back KayaArm from well below water level to a few inches above water level.
 - Centre the kayak, so the weight will be evenly distributed between the two arms.
 - Raise the front KayaArm until the kayak is out of the water, and raise the back KayaArm until the kayak is sitting level, and stored out of the water
 - Turn the kayak over. It is very important to make sure the kayak cannot fill with rainwater while stored on the KayaArms, as this could damage the kayak and/or KayaArms.
 - Secure the kayak to the KayaArms with straps or heavy duty stretch cords (not provided) about 40" in length.

- For heavier kayaks, a jig can be made to assist in lifting the chains – please see the FAQs at our website.
- <https://kayaarm.com/faq/>
- Winter storage on a shed or garage wall:
 - Remove both KayaArm assemblies from the dock.
 - Using one KayaArm assembly as a template install mounting brackets (one set for each arm spaced about 5 ft apart) on a wall as shown in the photos on our website in “Assembly Instructions” → “Winter Storage”
 - The materials (not provided) consist of common items such as short pieces of 2x4, screws and nails. This one time effort for installing these brackets enables quick seasonal mounting and dismounting of the KayaArm assemblies.
 - Mount the KayaArm assemblies onto the mounting brackets and adjust the arms to equal heights.
 - Place one kayak onto the arms and if needed hang another beneath them.
- Questions? Please go to our website at: <https://kayaarm.com/> and see our FAQ page

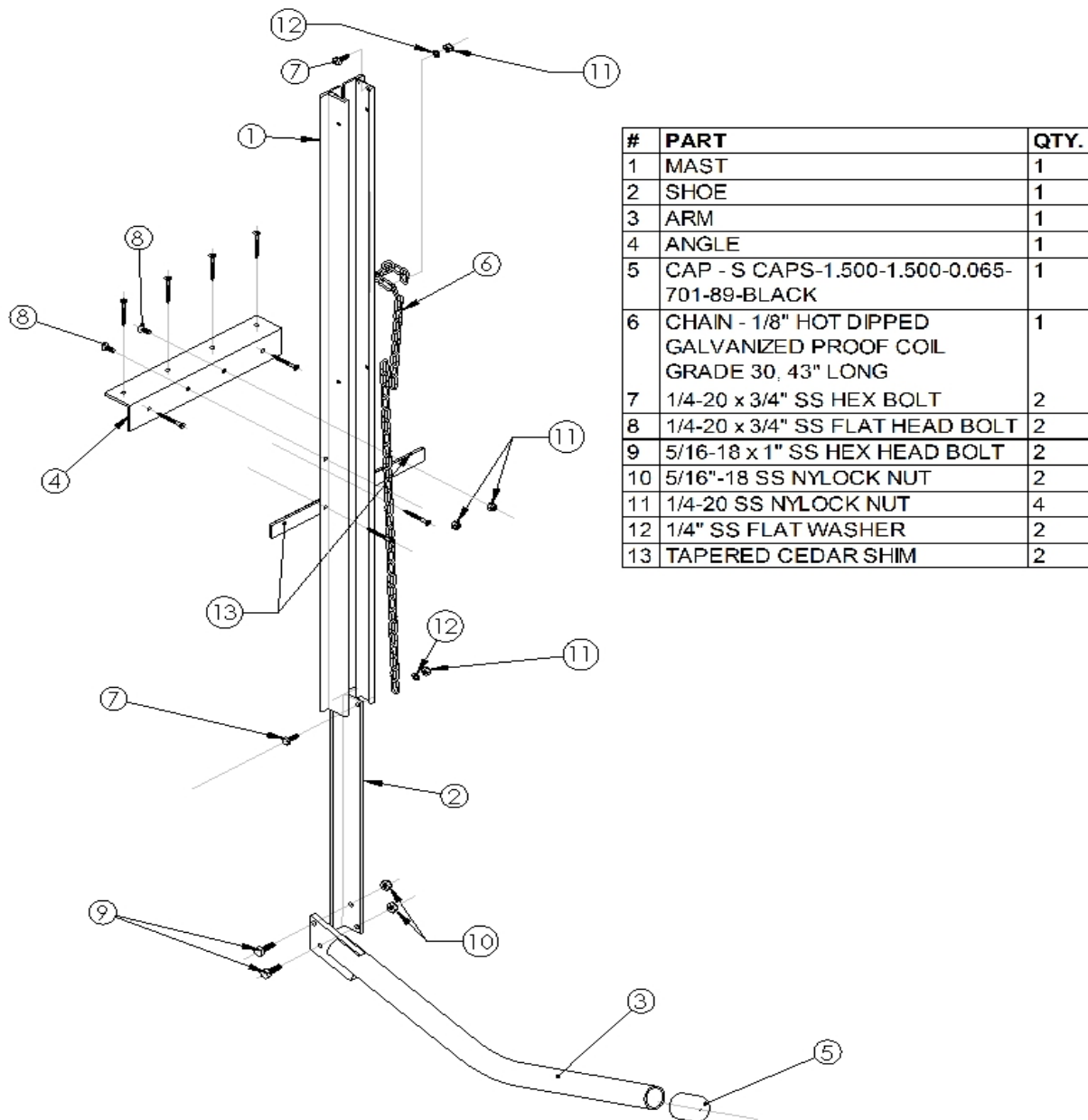

FIGURE 1

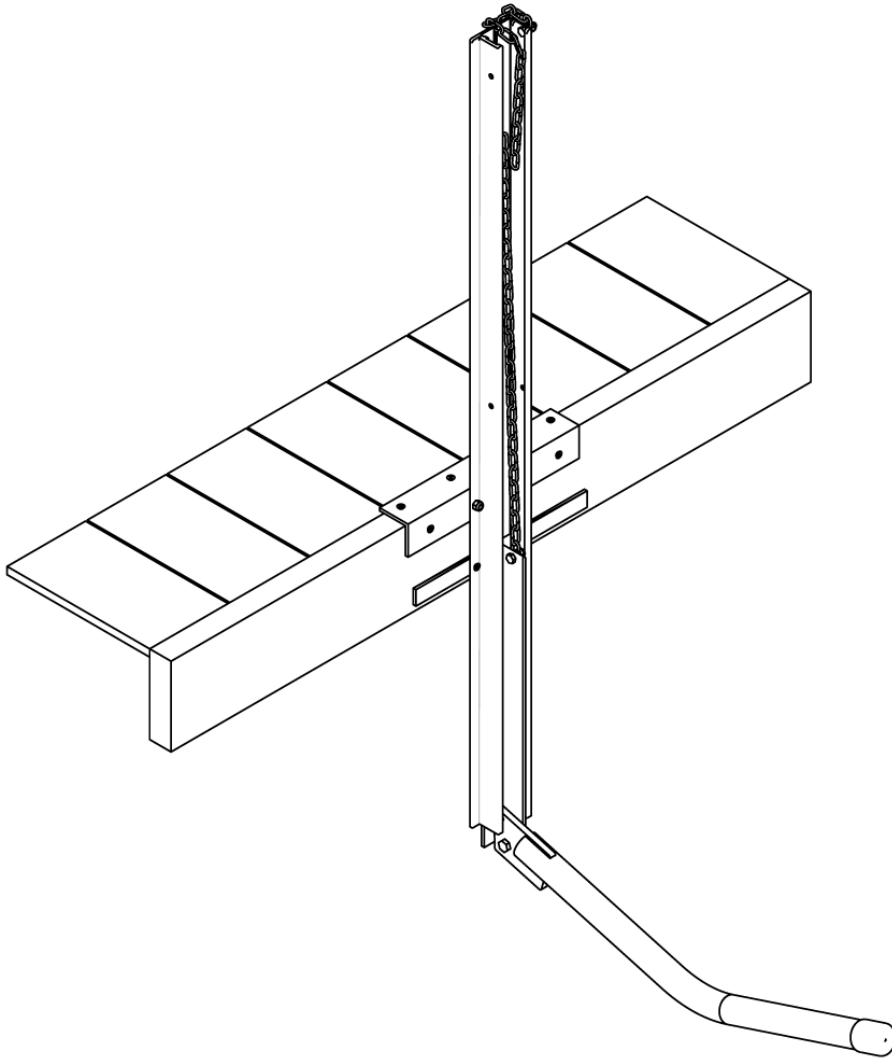

FIGURE 2